

Прожекторы серии SKY

- Корпус изготовлен из высокопрочного алюминиевого сплава, поверхность покрыта электростатическим напылением с пластиковой обработкой. Использована новейшая конструкция отвода и рассеивания тепла. Подходит для архитектурного, садового, ландшафтного освещения.
- Скрытая проводка безопасна, красива и надежна. Уровень защиты IP66;
- Вертикальный угол поворота 0 ~ 360°, горизонтальный 0 ~ 120°;
- Использование многоугольного распределения света подходит для освещения различных зданий, таких как колонны (широкие и узкие), стены, дома и мосты и т.д.

Три оси вращения

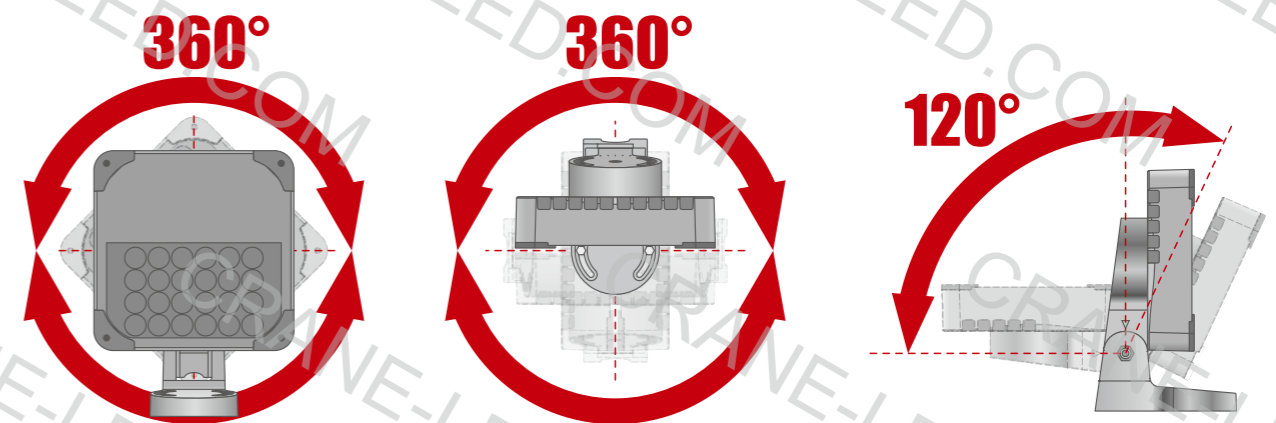

Антибликовое покрытие

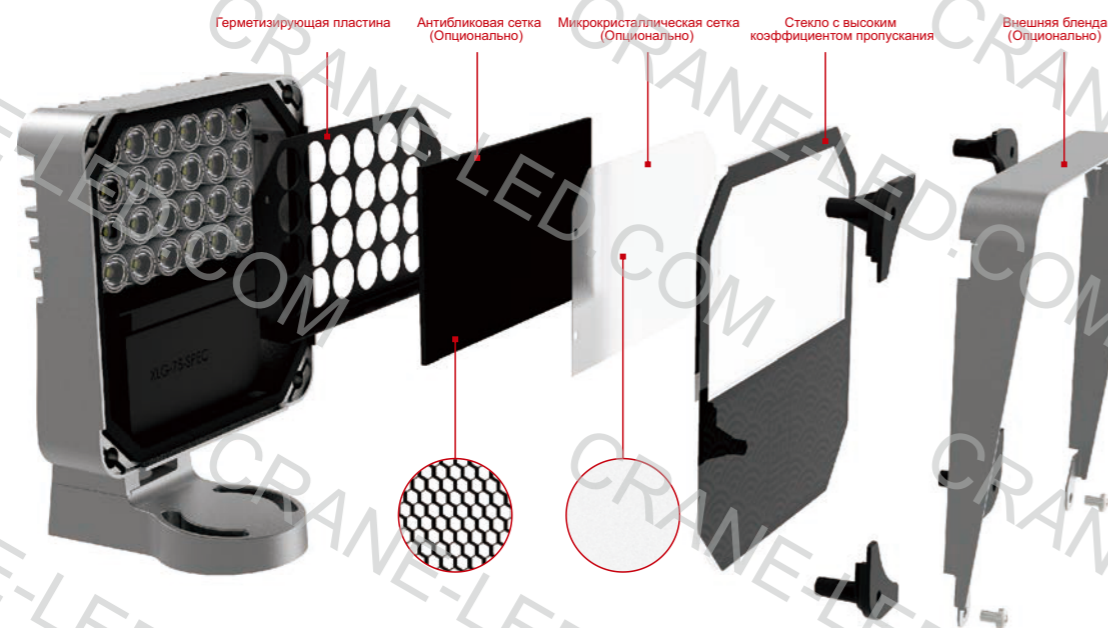

Гибкая настройка

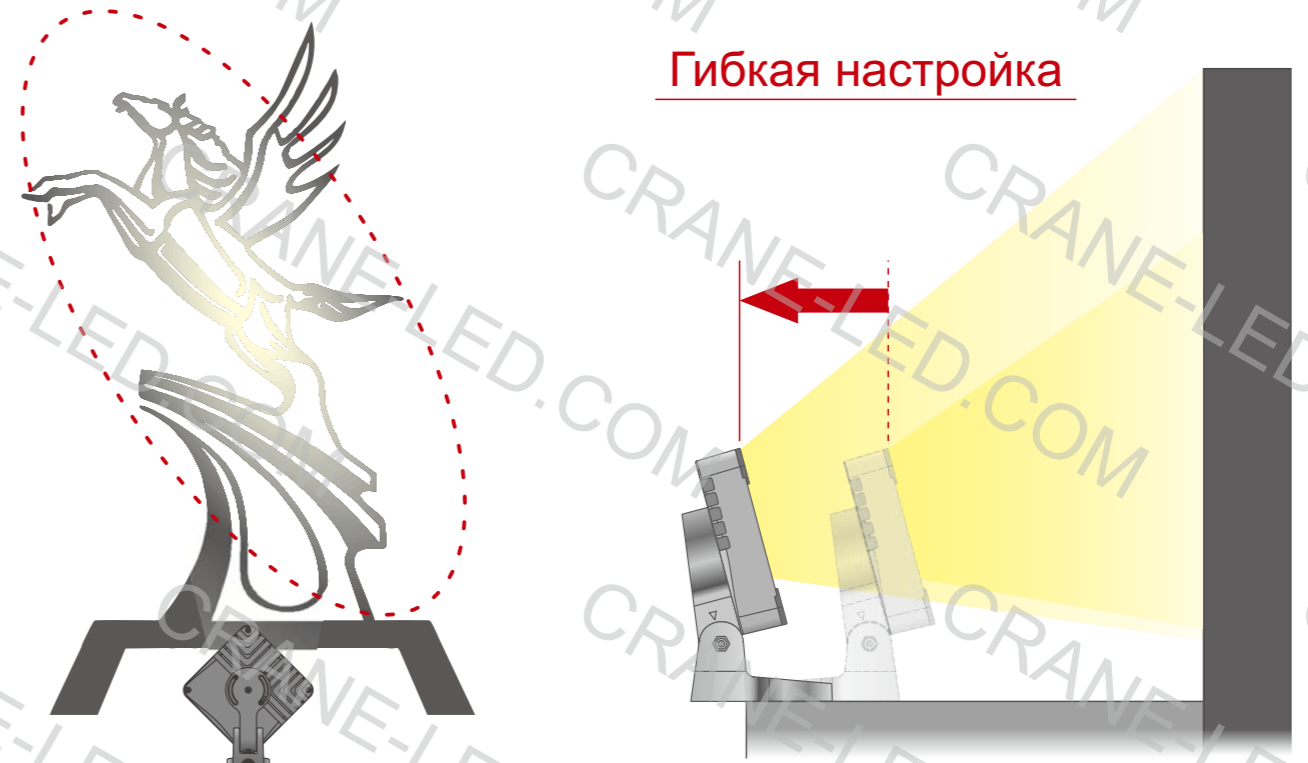

Ультратонкий

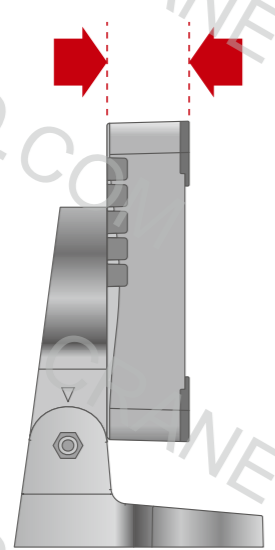

Скрытая проводка

Кабели и подключение скрыто внутри лампы



Суперраспределение света

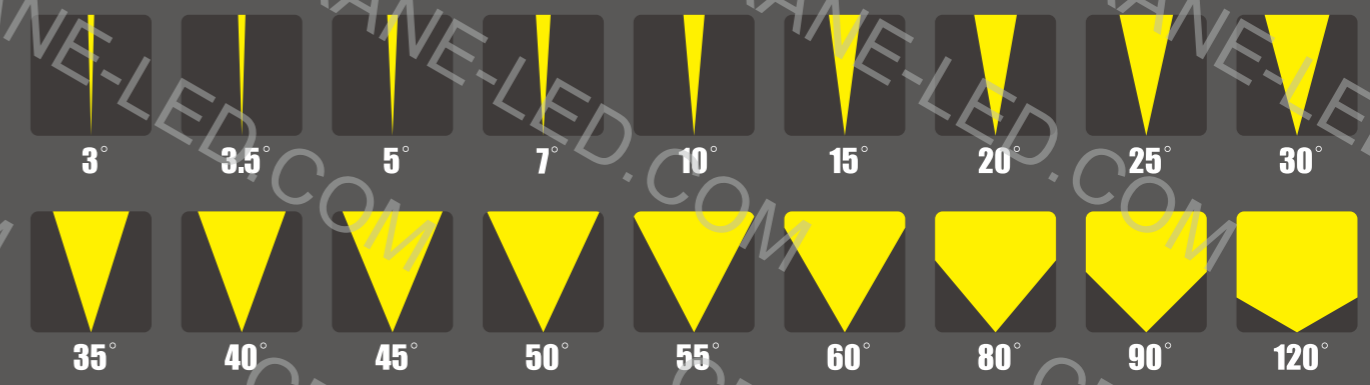

15 × 30°

15 × 45°

15 × 55°

30 × 60°

13 × 40°

4 × 50°



L02C-G

IP66 IK08 CE

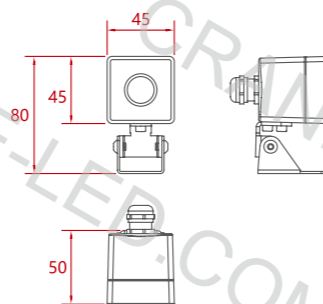
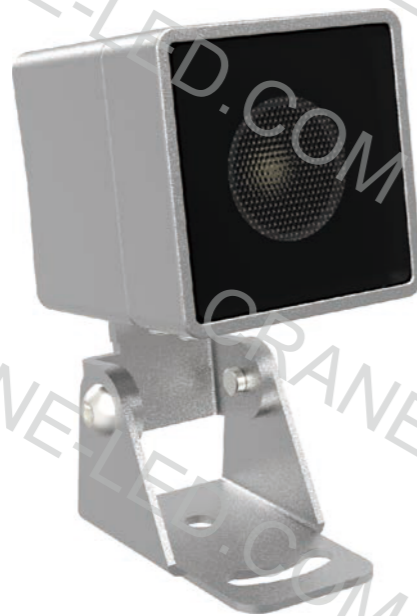

L02C-001G

DC 24V 3000/4000/5700K	Έρεε+άνοαί LED μινού	Ναοίαίε πώε	Ήρε+άνεεε οάε	Δαίαδ εάιυ	Άν ίαοί	Δαίαδ ίαεάεεε/ Άν άοοί
● ● ●	1	3 W	267 lm	7°/10°/15°/25°/40°/60°/90°/120° 15°/55°/15°/30°/15°/45° 4°/50°/13°/40°/30°/60°	80×50×45mm	0.3 kg
						0.4 kg/130×110×100 (1 υπ./γν.) 13.9 kg/520×390×260 (45 υπ./γν.)

L02C-001G 3W 10°

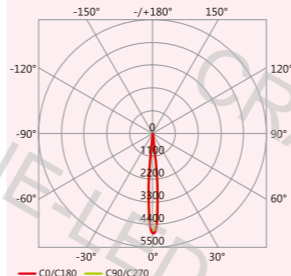

h(m)	Eavg(lx)	Emax(lx)	D(m)
1	3336	5162	0.18
2	834	1290	0.36
3	370	573	0.54
4	208	322	0.72
5	133	206	0.9

L02C-001G 3W 15°

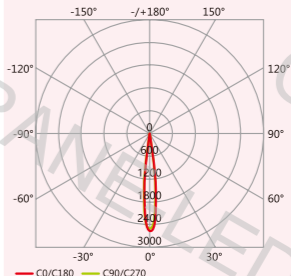

h(m)	Eavg(lx)	Emax(lx)	D(m)
1	1808	2695	0.24
2	451	673	0.39
3	200	299	0.73
4	113	168	0.97
5	72	107	1.121

L02C-001G 3W 25°

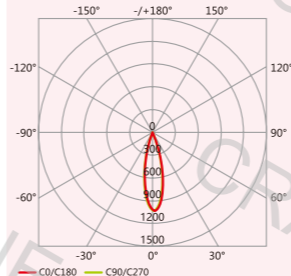

h(m)	Eavg(lx)	Emax(lx)	D(m)
1	706	1050	0.47
2	176	262	0.94
3	78	116	1.41
4	44	65	1.89
5	28	42	2.36

L02C-001G 3W 40°

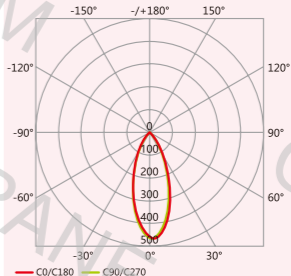

h(m)	Eavg(lx)	Emax(lx)	D(m)
1	306	469	0.68
2	76	117	1.37
3	34	52	2.05
4	19	29	2.74
5	12	18	3.42

L02C-001G 3W 60°

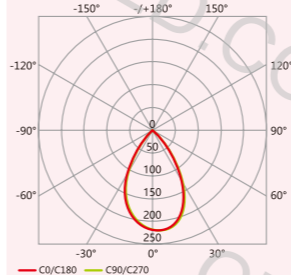

h(m)	Eavg(lx)	Emax(lx)	D(m)
1	133	220	1.18
2	33	55	2.37
3	14	24	3.55
4	8	13	4.74
5	5	9	5.93

L02C-001G 3W 120°

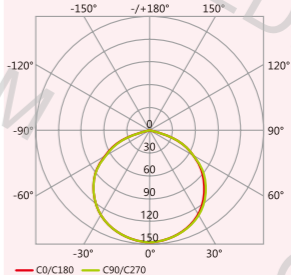

h(m)	Eavg(lx)	Emax(lx)	D(m)
1	21	73	3.07
2	5	18	6.14
3	2	8	9.21
4	1	4	12.29
5	1	3	15.36

L02C-001G 3W 15×55°

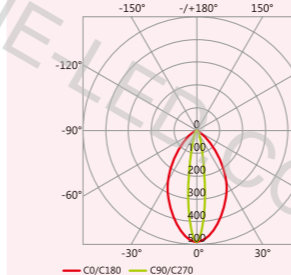

L02C-001G 3W 15×30°

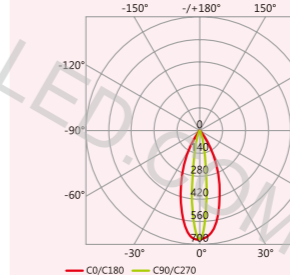

L02C-001G 3W 12×25°

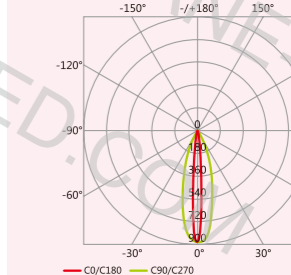

L02C-001G 3W 30×60°

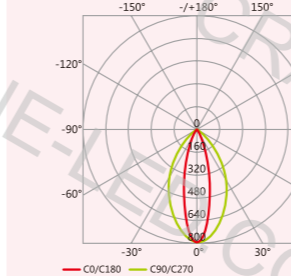

L02C-001G 3W 4×50°

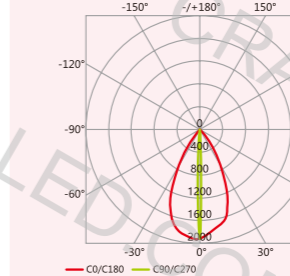

L02C-001G 3W 15×40°

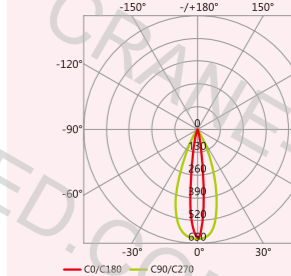

L02C-F

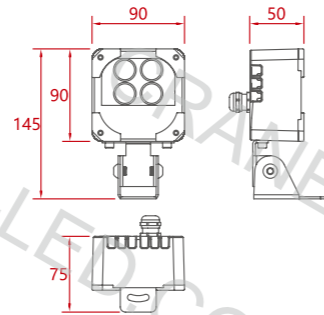

L02C-001F

DC 24V 3000/4000/5700K	Έξοχή+απόαί LED	Μικρόν	Νααοίαιε ποίε	Προε+αθέεε οαίε	Ώαίαδ εαίιυ	Άαη ίαδοί	Ώαίαδ οίαείαεε/ Άαη άδooί
● ● ●	1	3 W	203 lm	3°/5°	145×90×75mm	0.8 kg	0.9 kg/240×150×120(1 υπρ./γπ.) 1.1 kg/440×350×250(9 υπρ./γπ.)

L02C-004F

DC 24V 3000/4000/5700K	Έξοχή+απόαί LED	Μικρόν	Νααοίαιε ποίε	Προε+αθέεε οαίε	Ώαίαδ εαίιυ	Άαη ίαδοί	Ώαίαδ οίαείαεε/ Άαη άδooί
● ● ●	4	9 W	813 lm	7°/10°/15°/25°/40°/60°/90°/120° 15°x55°/15°x30°/15°x45° 4°x50°/13°x40°/30°x60°	145×90×75mm	0.8 kg	0.9 kg/240×150×120(1 υπρ./γπ.) 1.1 kg/440×350×250(9 υπρ./γπ.)

L02C-001F 3W 3°

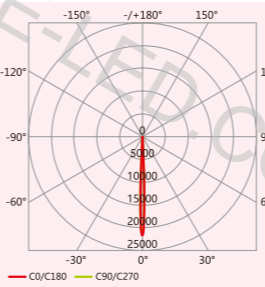

h(m)	Eavg(lx)	Emax(lx)	D(m)
1	1618	21933	0.05
2	3545	5483	0.11
3	1576	2437	0.16
4	886	1371	0.22
5	567	877	0.27

L02C-001F 3W 5°

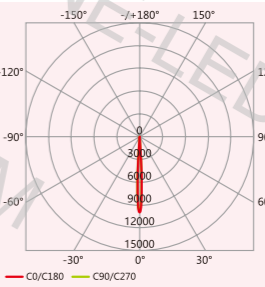

h(m)	Eavg(lx)	Emax(lx)	D(m)
1	6814	10149	0.09
2	1703	2537	0.18
3	757	1128	0.27
4	425	634	0.36
5	272	405	0.45

L06B-004F 9W 10°

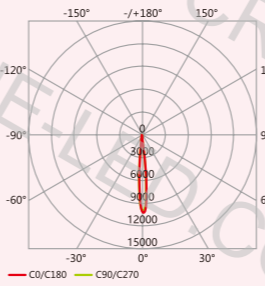

h(m)	Eavg(lx)	Emax(lx)	D(m)
1	7005	10840	0.18
2	1751	2710	0.36
3	778	1204	0.54
4	437	677	0.72
5	280	433	0.9

L02C-004F 9W 15°

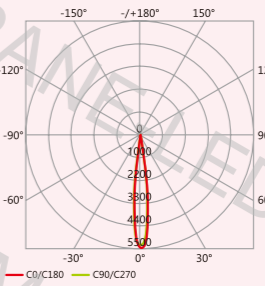

h(m)	Eavg(lx)	Emax(lx)	D(m)
1	3778	5632	0.24
2	944	1408	0.39
3	419	625	0.73
4	236	352	0.97
5	151	225	1.121

L02C-004F 9W 25°

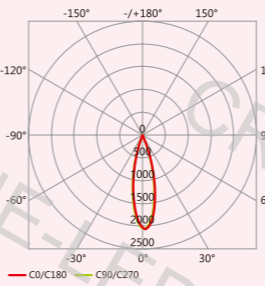

h(m)	Eavg(lx)	Emax(lx)	D(m)
1	1414	2099	0.47
2	353	524	0.94
3	157	233	1.41
4	88	131	1.89
5	56	83	2.36

L02C-004F 9W 40°

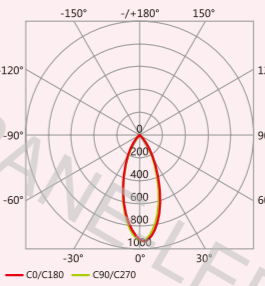

h(m)	Eavg(lx)	Emax(lx)	D(m)
1	627	962	0.68
2	156	240	1.37
3	69	107	2.05
4	39	60	2.74
5	25	38	3.42

L02C-004F 9W 60°

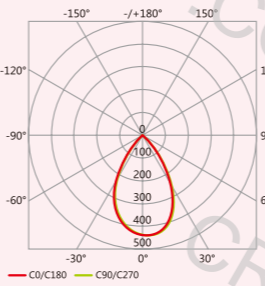

h(m)	Eavg(lx)	Emax(lx)	D(m)
1	272	452	1.18
2	68	113	2.37
3	30	50	3.55
4	17	28	4.74
5	10	18	5.93

L02C-004F 9W 120°

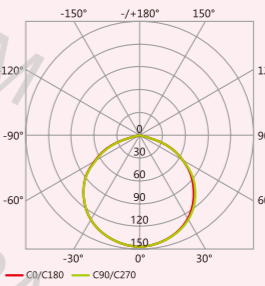

h(m)	Eavg(lx)	Emax(lx)	D(m)
1	43	147	3.07
2	10	36	6.14
3	4	16	9.21
4	2	9	12.29
5	1	5	15.36

L02C-004F 9W 15x55°

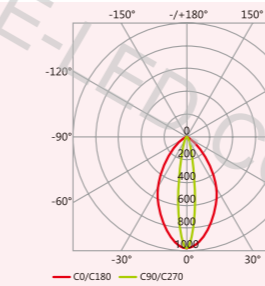

L02C-004F 9W 15x30°

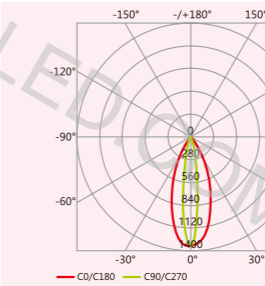

L02C-004F 9W 12x25°

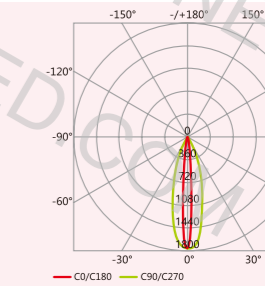

L02C-004F 9W 30x60°

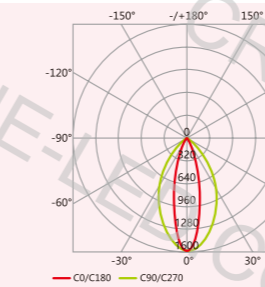

L02C-004F 9W 4x50°

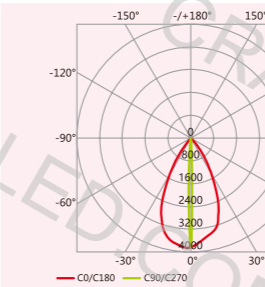

L02C-004F 9W 15x40°

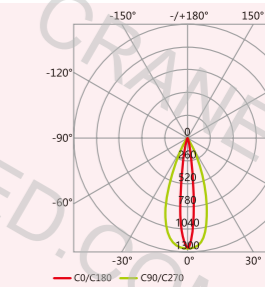

L02C-D

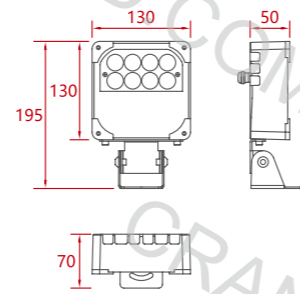
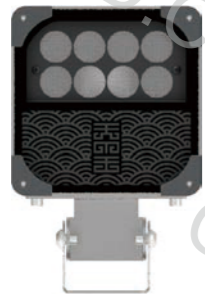
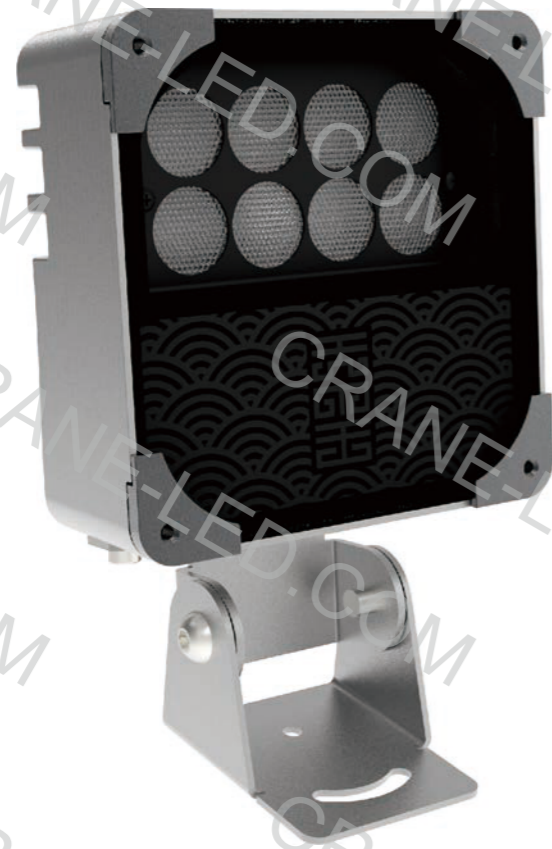

L02C-002D

DC 24V



Έιέε+άνοαί LED τίνου	Νάαοιάιέ τίνιέ	Ίιρέ+άνέέε όαίε	΢α΢ιάθ έαίιυ	Άάν ιάοοί	΢α΢ιάθ όιαέιάέε/ Άάν άόόοί
2 RGBW	20 W	718 lm	15°/25°/40°/60°	235×160×130mm	1.2 kg 1.4 kg/230×210×130 (1 ιιτ./γν.) 7.6 kg/440×350×250 (6 ιιτ./γν.)

L02C-006D

AC 220V
3000/4000/5700K



Έιέε+άνοαί LED τίνου	Νάαοιάιέ τίνιέ	Ίιρέ+άνέέε όαίε	΢α΢ιάθ έαίιυ	Άάν ιάοοί	΢α΢ιάθ όιαέιάέε/ Άάν άόόοί
6	14 W	855 lm	3°/5°	235×160×130mm	1.3 kg 1.5 kg/230×210×130 (1 ιιτ./γν.) 8.2 kg/440×350×250 (6 ιιτ./γν.)

L02C-008D

AC 220V
3000/4000/5700K



Έιέε+άνοαί LED τίνου	Νάαοιάιέ τίνιέ	Ίιρέ+άνέέε όαίε	΢α΢ιάθ έαίιυ	Άάν ιάοοί	΢α΢ιάθ όιαέιάέε/ Άάν άόόοί
8	18 W	1481 lm	7°/10°/15°/25°/40°/60°/90°/120° 15×55°/15×30°/15×45° 4×50°/15×40°/30×60°	235×160×130mm	1.3 kg 1.5 kg/230×210×130 (1 ιιτ./γν.) 8.2 kg/440×350×250 (6 ιιτ./γν.)

L02C-006D 14W 3°

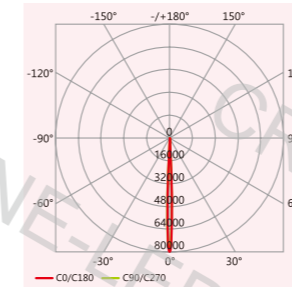

h(m)	Eavg(lx)	Emax(lx)	D(m)
1	51944	80349	0.05
2	12986	20087	0.11
3	3247	5022	0.16
4	1443	2232	0.22
5	519	803	0.27

L02C-006D 14W 5°

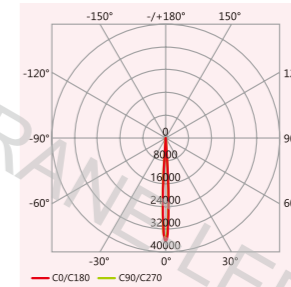

h(m)	Eavg(lx)	Emax(lx)	D(m)
1	24988	37219	0.09
2	6247	9305	0.18
3	2776	4135	0.27
4	1562	2326	0.36
5	999	1489	0.45

L02C-008D 18W 10°

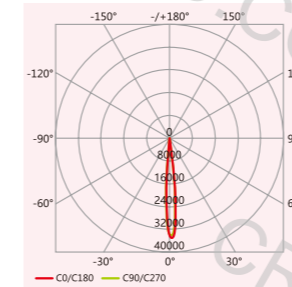

h(m)	Eavg(lx)	Emax(lx)	D(m)
1	23536	36419	0.18
2	5884	9105	0.36
3	2615	4047	0.54
4	1471	2276	0.72
5	941	1457	0.9

L02C-008D 18W 15°

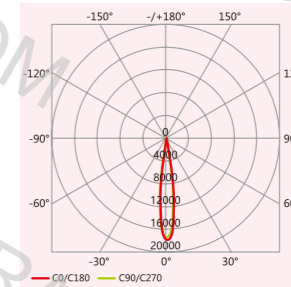

h(m)	Eavg(lx)	Emax(lx)	D(m)
1	12591	18770	0.24
2	3148	4692	0.39
3	1399	2086	0.73
4	787	1173	0.97
5	503	750	1.121

L02C-008D 18W 25°

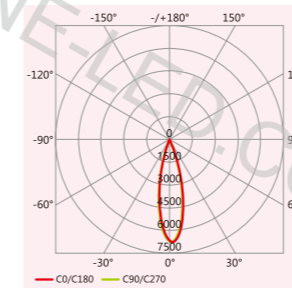

h(m)	Eavg(lx)	Emax(lx)	D(m)
1	4712	6998	0.47
2	1178	1750	0.94
3	523	777	1.41
4	294	437	1.89
5	188	279	2.36

L02C-008D 18W 40°

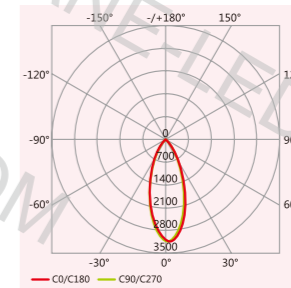

h(m)	Eavg(lx)	Emax(lx)	D(m)
1	2091	3209	0.68
2	522	802	1.37
3	232	356	2.05
4	130	200	2.74
5	83	128	3.42

L02C-008D 18W 60°

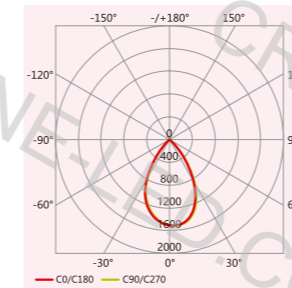

h(m)	Eavg(lx)	Emax(lx)	D(m)
1	908	1508	1.18
2	227	376	2.37
3	101	167	3.55
4	56	94	4.74
5	36	60	5.93

L02C-008D 18W 120°

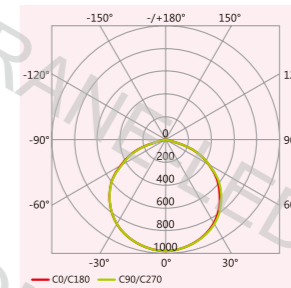

h(m)	Eavg(lx)	Emax(lx)	D(m)
1	143	490	3.07
2	35	122	6.14
3	15	54	9.21
4	8	30	12.29
5	5	19	15.36

L02C-B



IP66 IK08 CE

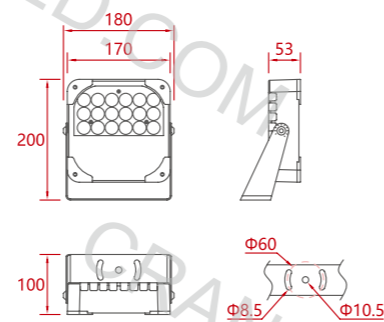
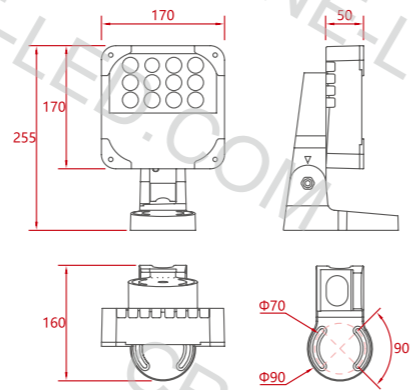
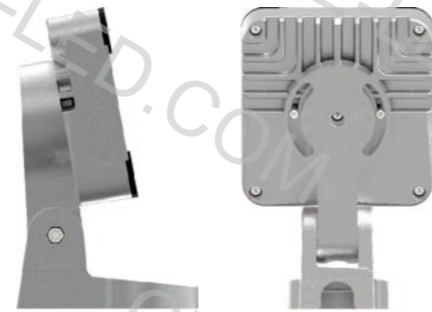

L02C-004B

AC 220V



Έίεε+άνοαί LEDίνου	Νάαοίαίε ήοίε	Ίιόε+άνέεε όαίε	΢αείαδ εαίιυ	Άαη ιαόοί	΢αείαδ οίαείαέε/ Άαη άόόοί
4pcs/RGBW	40 W	1424 lm	15°/25°/40°/60°	255×170×160mm	2.4 kg 2.6 kg/320×270×190 (1 υπ./γν.) 9.9 kg/540×370×320 (4 υπ./γν.)

L02C-008B

AC 220V
3000/4000/5700K



Έίεε+άνοαί LEDίνου	Νάαοίαίε ήοίε	Ίιόε+άνέεε όαίε	΢αείαδ εαίιυ	Άαη ιαόοί	΢αείαδ οίαείαέε/ Άαη άόόοί
8 pcs	25 W	1625 lm	3°/5°	255×170×160mm	2.4 kg 2.6 kg/320×270×190 (1 υπ./γν.) 9.9 kg/540×370×320 (4 υπ./γν.)

L02C-018B

AC220V
3000/4000K/RGB



Έίεε+άνοαί LEDίνου	Νάαοίαίε ήοίε	Ίιόε+άνέεε όαίε	΢αείαδ εαίιυ	Άαη ιαόοί	΢αείαδ οίαείαέε/ Άαη άόόοί
18 pcs	40 W	3817 lm	7°/10°/15°/25°/40°/60°/90°/120° 15°/55°/15°/30°/15°/45° 4°/50°/13°/40°/30°/60°	255×170×160mm	2.5 kg 2.7 kg/320×270×190 (1 υπ./γν.) 10.3 kg/540×370×320(4 υπ./γν.)

L02C-008B 25W 3°

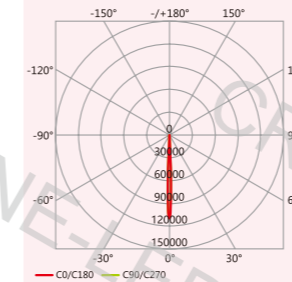

h(m)	Eavg(lx)	Emax(lx)	D(m)
2	17723	27415	0.11
4	4431	6854	0.22
6	1969	3046	0.33
8	1108	1713	0.44
10	708	1097	0.55

L02C-008B 25W 5°

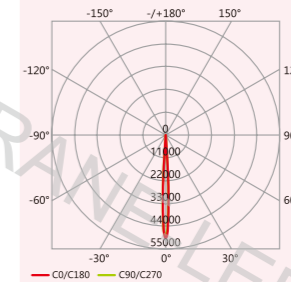

h(m)	Eavg(lx)	Emax(lx)	D(m)
2	8516	12684	0.18
4	2129	3171	0.36
6	946	1409	0.54
8	532	792	0.73
10	340	507	0.89

L02C-018B 40W 10°

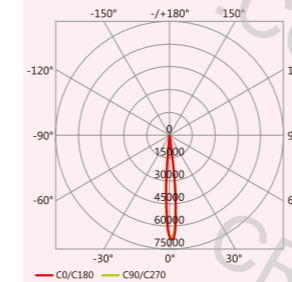

h(m)	Eavg(lx)	Emax(lx)	D(m)
2	11768	18210	0.35
4	2942	4552	0.71
6	1308	2023	1.07
8	735	2023	1.43
10	470	1138	1.79

L02C-018B 40W 15°

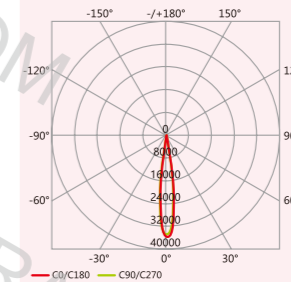

h(m)	Eavg(lx)	Emax(lx)	D(m)
2	6296	9385	0.48
4	1574	2346	0.96
6	699	1043	1.45
8	393	586	1.93
10	251	375	2.42

L02C-018B 40W 25°

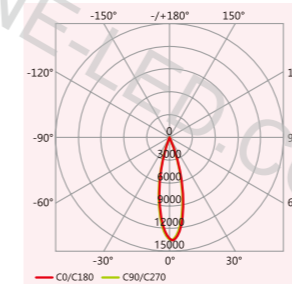

h(m)	Eavg(lx)	Emax(lx)	D(m)
2	2356	3499	0.95
4	589	874	1.9
6	261	388	2.85
8	147	218	3.8
10	94	140	4.75

L02C-018B 40W 40°

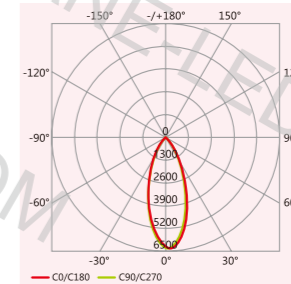

h(m)	Eavg(lx)	Emax(lx)	D(m)
2	1046	1604	1.37
4	261	401	2.74
6	116	178	4.11
8	65	100	5.48
10	41	64	6.85

L02C-018B 40W 60°

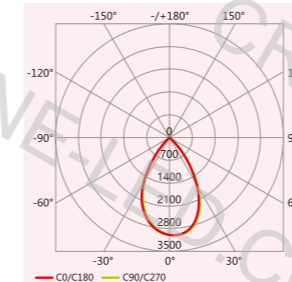

h(m)	Eavg(lx)	Emax(lx)	D(m)
2	454	763	2.37
4	113	188	4.74
6	50	83	7.11
8	28	47	9.48
10	18	30	11.86

L02C-018B 40W 120°

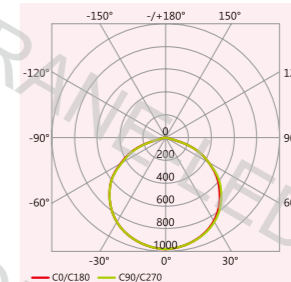

h(m)	Eavg(lx)	Emax(lx)	D(m)
1	287	980	3.07
2	71	980	6.14
3	31	109	9.21
4	17	61	12.29
5	11	39	15.36

L02C-A

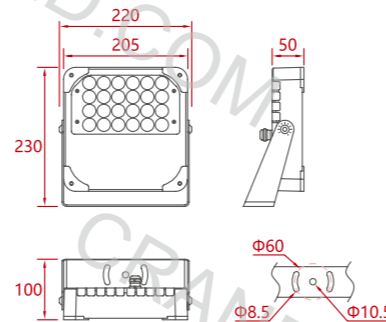
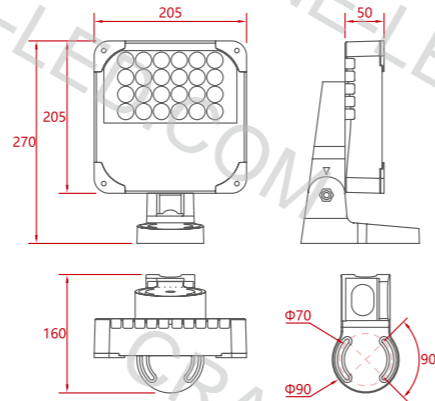
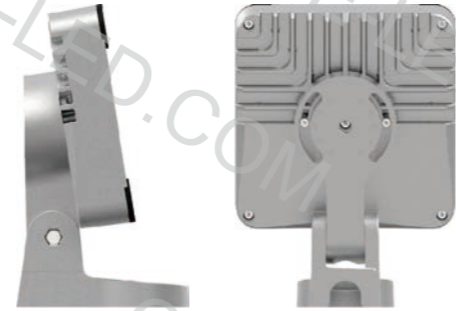

L02C-006A

AC 220V	Έίρε+απόαι LEDπινού	Νάαοιαιέ πιοιέ	Ίρε+αήεεε οάιέ	Ώααίαδ εάιιυ	Άαη ιαοοί	Ώααίαδ οιαείαεε/ Άαη αοοοοί
	6pcs/RGBW	60 W	2142 lm	15°/25°/40°/60°	270×205×160mm	3.0 kg 3.2 kg/340×340×190(1 πρ./γν.) 9.4 kg/540×370×320(3 πρ./γν.)

L02C-012A

AC 220V 3000/4000/5700K	Έίρε+απόαι LEDπινού	Νάαοιαιέ πιοιέ	Ίρε+αήεεε οάιέ	Ώααίαδ εάιιυ	Άαη ιαοοί	Ώααίαδ οιαείαεε/ Άαη αοοοοί
	12 pcs	40 W	2728 lm	3°/5°	270×205×160mm	3.0 kg 3.2 kg/340×340×190(1 πρ./γν.) 9.4 kg/540×370×320(3 πρ./γν.)

L02C-024A

AC 220V 3000/4000K/RGBW	Έίρε+απόαι LEDπινού	Νάαοιαιέ πιοιέ	Ίρε+αήεεε οάιέ	Ώααίαδ εάιιυ	Άαη ιαοοί	Ώααίαδ οιαείαεε/ Άαη αοοοοί
	24 pcs	60 W	5192 lm	7°/10°/15°/28°/40°/60°/90°/120° 15°/55°/15°/30°/15°/45° 4°/60°/15°/40°/30°/60°	270×205×160mm	3.1 kg 3.3 kg/340×340×190 (1 πρ./γν.) 9.7 kg/540×370×320 (3 πρ./γν.)

L02C-012A 40W 3°

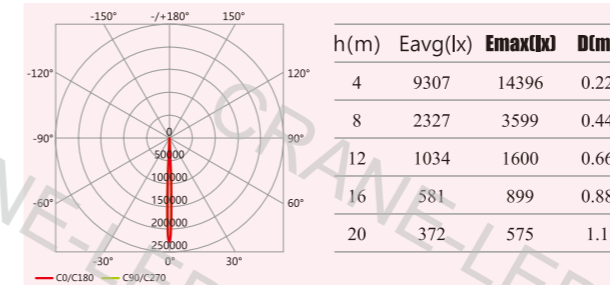

L02C-012A 40W 5°

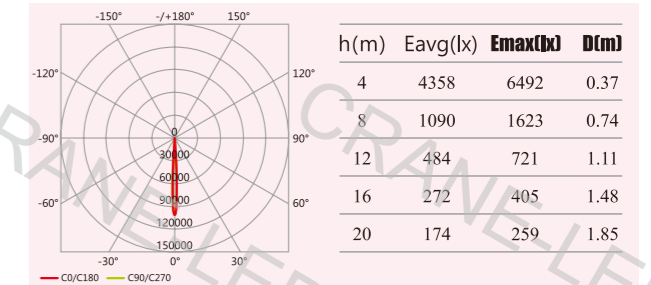

L02C-024A 60W 7°

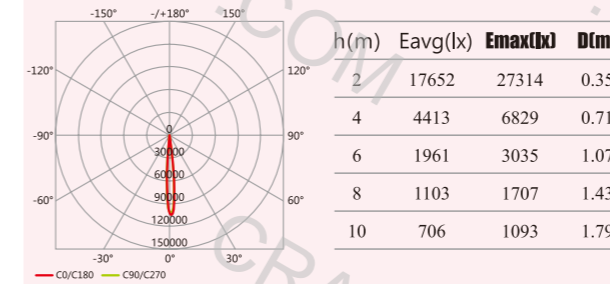

L02C-024A 60W 15°

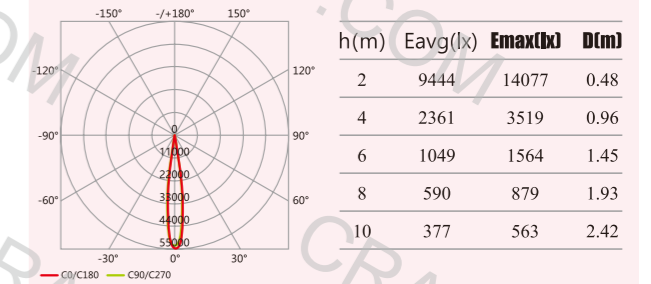

L02C-024A 60W 25°

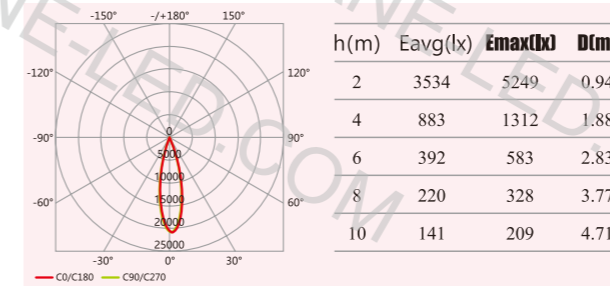

L02C-024A 60W 40°

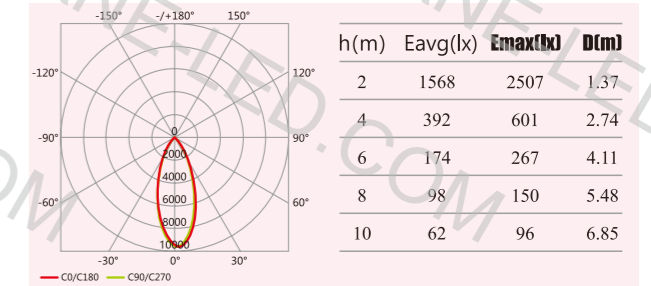

L02C-024A 60W 60°

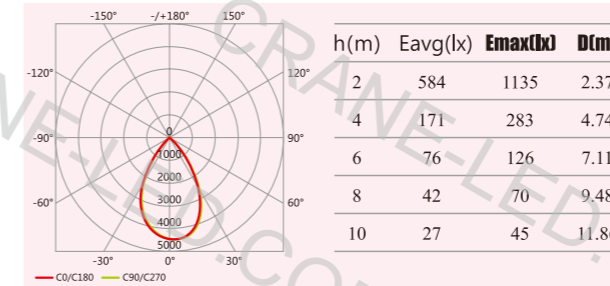

L02C-024A 60W 120°

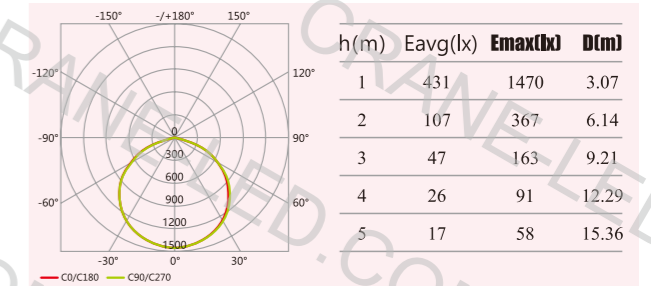

L02C-C

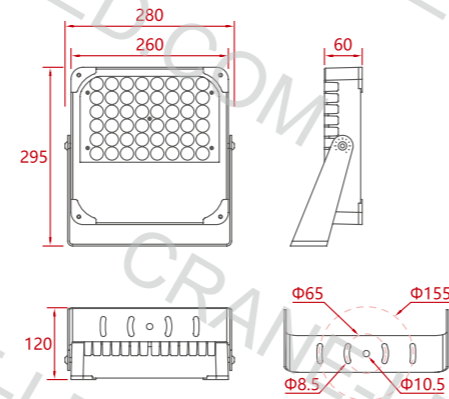
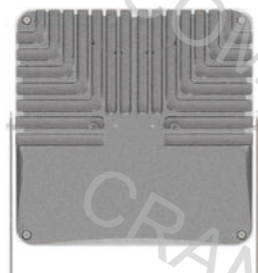
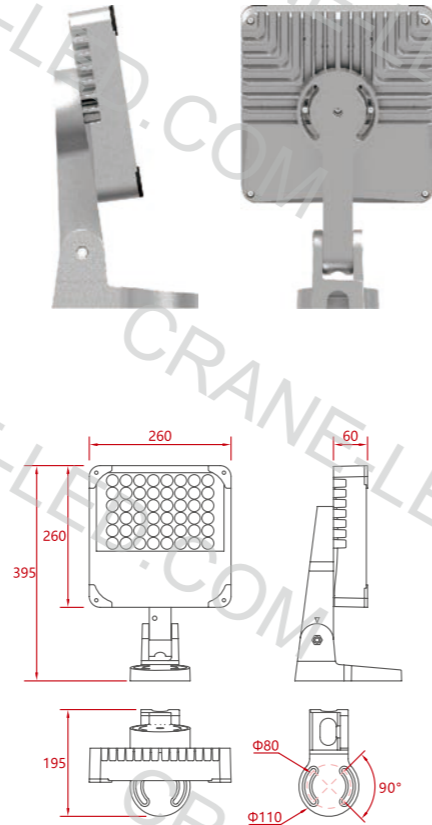

L02C-009C

AC 220V	Éιέε+άηοάι LED ηίνου	Νάαοίαιέ ηιόιέ	Ίιρέ+άηέέέ οάιέ	Ðαçiάð εάηιυ	Άάη ιάοòι	Ðαçiάð òιαέιάέè/ Άάη áðòòòι
9/RGBW	80 W	2752 lm	15°/25°/40°/60°	395×260×195mm	5.1 kg	5.4 kg/430×240×300(1 ηηρ./γη.) 10.7 kg/480×460×420(2 ηηρ./γη.)

L02C-012C

AC 220V	Éιέε+άηοάι LED ηίνου	Νάαοίαιέ ηιόιέ	Ίιρέ+άηέέέ οάιέ	Ðαçiάð εάηιυ	Άάη ιάοòι	Ðαçiάð òιαέιάέè/ Άάη áðòòòι
12/RGBW	100 W	3670 lm	15°/25°/40°/60°	395×260×195mm	5.2 kg	5.5 kg/430×240×300(1 ηηρ./γη.) 10.9 kg/480×460×420(2 ηηρ./γη.)

L02C-024C

AC 220V 3000/4000/5700K	Éιέε+άηοάι LED ηίνου	Νάαοίαιέ ηιόιέ	Ίιρέ+άηέέέ οάιέ	Ðαçiάð εάηιυ	Άάη ιάοòι	Ðαçiάð òιαέιάέè/ Άάη áðòòòι
24	80 W	5279 lm	3°/5°	395×260×195mm	5.3 kg	5.6 kg/430×240×300(1 ηηρ./γη.) 11.1 kg/480×460×420(2 ηηρ./γη.)

L02C-036C

AC 220V 3000/4000K/RGBW	Éιέε+άηοάι LED ηίνου	Νάαοίαιέ ηιόιέ	Ίιρέ+άηέέέ οάιέ	Ðαçiάð εάηιυ	Άάη ιάοòι	Ðαçiάð òιαέιάέè/ Άάη áðòòòι
36	80 W	7400 lm	7°/10°/15°/25°/40°/60°/90°/120° 15°/55°/15°/30°/15°/45° 4°/50°/13°/40°/30°/60°	395×260×195mm	5.4 kg	5.7 kg/430×240×300(1 ηηρ./γη.) 11.3 kg/480×460×420(2 ηηρ./γη.)

L02C-048C

AC 220V 3000/4000K/RGBW	Éιέε+άηοάι LED ηίνου	Νάαοίαιέ ηιόιέ	Ίιρέ+άηέέέ οάιέ	Ðαçiάð εάηιυ	Άάη ιάοòι	Ðαçiάð òιαέιάέè/ Άάη áðòòòι
48	100 W	9867 lm	7°/10°/15°/25°/40°/60°/90°/120° 15°/55°/15°/30°/15°/45° 4°/50°/13°/40°/30°/60°	395×260×195mm	5.5 kg	5.8 kg/430×240×300(1 ηηρ./γη.) 11.5 kg/480×460×420(2 ηηρ./γη.)

L02C-024C 80W 3°

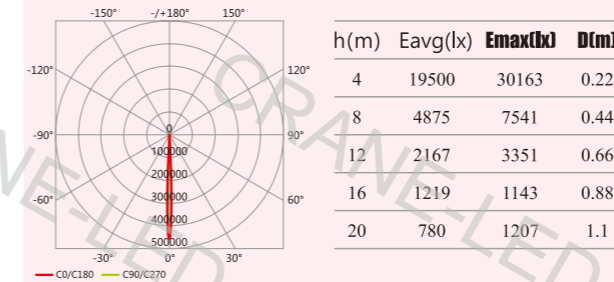

L02C-024C 80W 5°

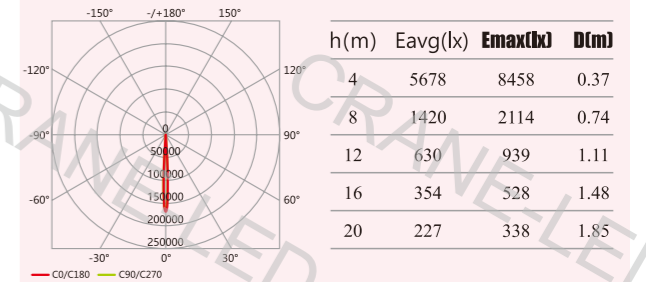

L02C-048C 100W 7°

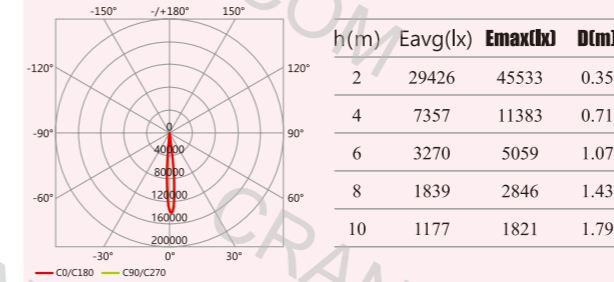

L02C-048C 100W 15°

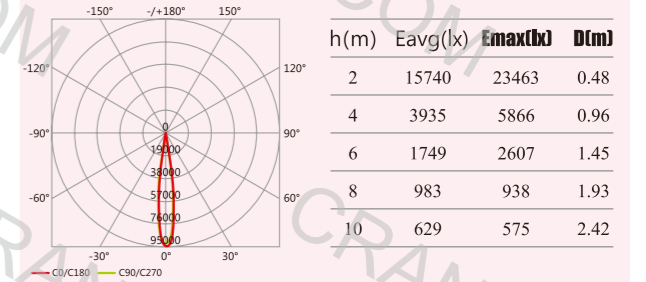

L02C-048C 100W 25°

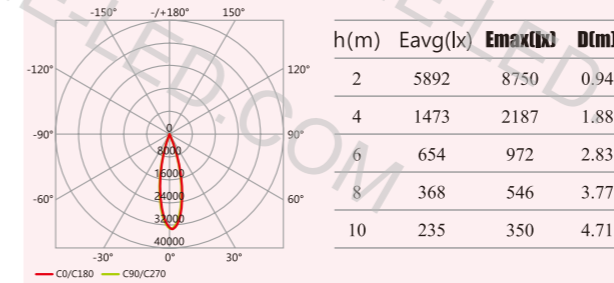

L02C-048C 100W 40°

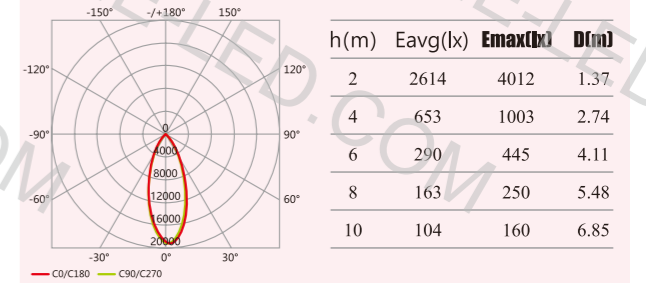

L02C-048C 100W 60°

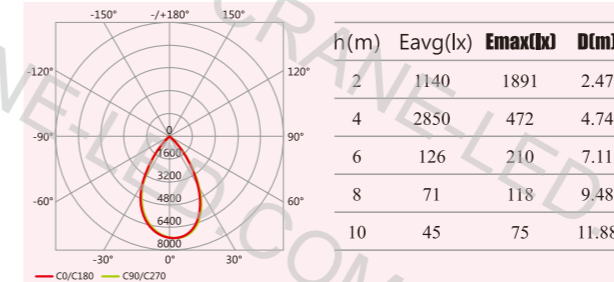

L02C-048C 100W 120°

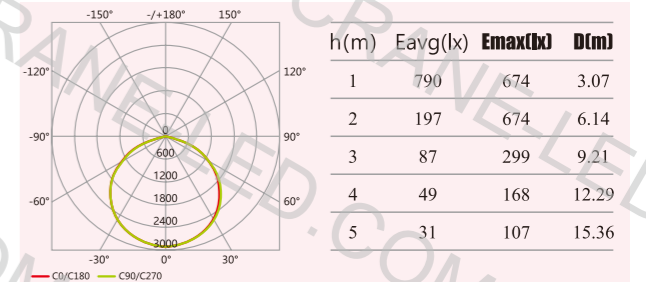

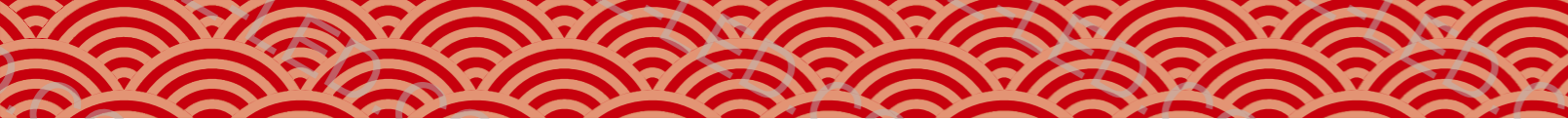

L02C-E



IP66 IK08 CE

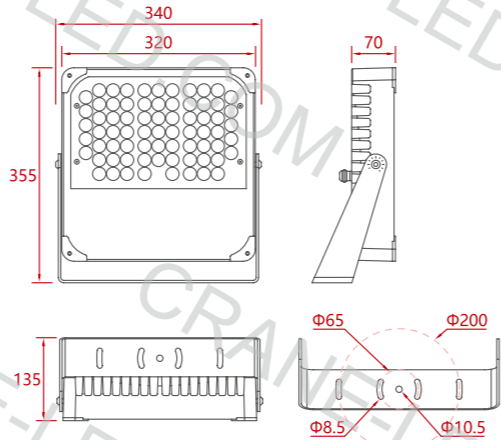
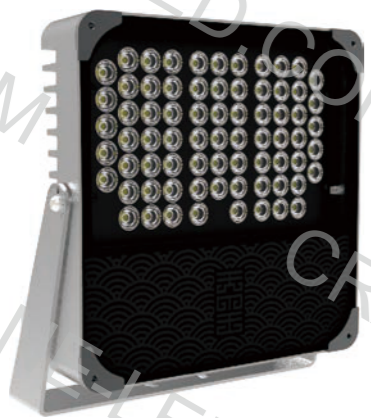
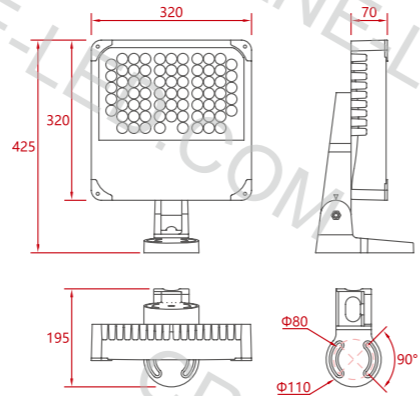
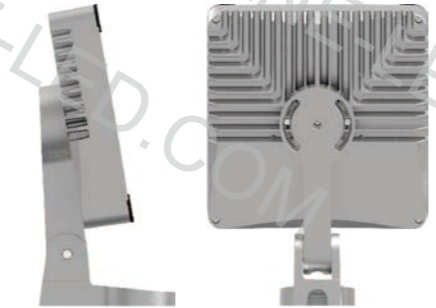

L02C-016E

AC 220V	Éιέε+αηοαί LEDινού	Νάαοιαιέ ιϊοιέ	Ίιόε+αηέεε οαίε	Ðαçiαð εαίιυ	Άαη ιαòοί	Ðαçiαð οíαεíαιέε/ Άαη αòòοί
16/RGBW	120 W	4340 lm	15°/25°/40°/60°	425×320×195mm	7.0 kg	7.9 kg/520×390×260(1 ιηη./γη.)

L02C-020E

AC 220V	Éιέε+αηοαί LEDινού	Νάαοιαιέ ιϊοιέ	Ίιόε+αηέεε οαίε	Ðαçiαð εαίιυ	Άαη ιαòοί	Ðαçiαð οíαεíαιέε/ Άαη αòòοί
20/RGBW	150 W	5425 lm	15°/25°/40°/60°	425×320×195mm	7.2 kg	8.1 kg/520×390×260(1 ιηη./γη.)

L02C-032E

AC 220V 3000/4000/5700K	Éιέε+αηοαί LEDινού	Νάαοιαιέ ιϊοιέ	Ίιόε+αηέεε οαίε	Ðαçiαð εαίιυ	Άαη ιαòοί	Ðαçiαð οíαεíαιέε/ Άαη αòòοί
32	100 W	6779 lm	3°/5°	425×320×195mm	7.4 kg	8.3 kg/520×390×260(1 ιηη./γη.)

L02C-056E

AC 220V 3000/4000K/RGBW	Éιέε+αηοαί LEDινού	Νάαοιαιέ ιϊοιέ	Ίιόε+αηέεε οαίε	Ðαçiαð εαίιυ	Άαη ιαòοί	Ðαçiαð οíαεíαιέε/ Άαη αòòοί
56	120 W	11503 lm	7°/10°/15°/25°/40°/60°/90°/120° 15×55°/15×30°/15×45° 4×50°/13×40°/30×60°	425×320×195mm	7.5 kg	8.4 kg/520×390×260(1 ιηη./γη.)

L02C-072E

AC 220V 3000/4000K/RGBW	Éιέε+αηοαί LEDινού	Νάαοιαιέ ιϊοιέ	Ίιόε+αηέεε οαίε	Ðαçiαð εαίιυ	Άαη ιαòοί	Ðαçiαð οíαεíαιέε/ Άαη αòòοί
72	150 W	14791 lm	7°/10°/15°/25°/40°/60°/90°/120° 15×55°/15×30°/15×45° 4×50°/13×40°/30×60°	425×320×195mm	7.6 kg	8.5 kg/520×390×260(1 ιηη./γη.)

L02C-032E 100W 3°

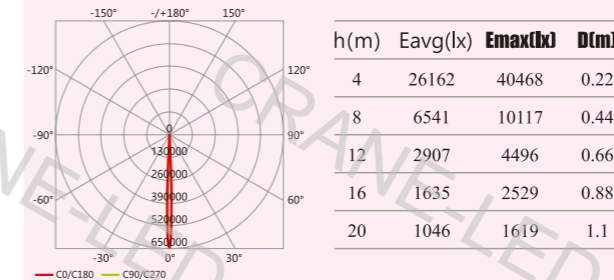

L02C-032E 100W 5°

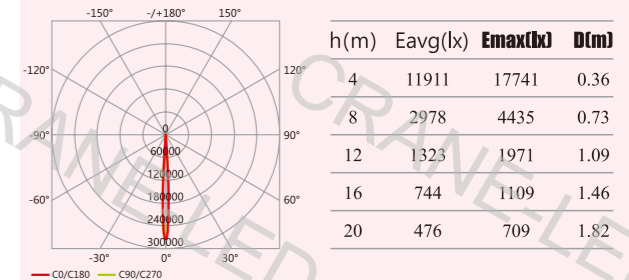

L02C-072E 150W 7°

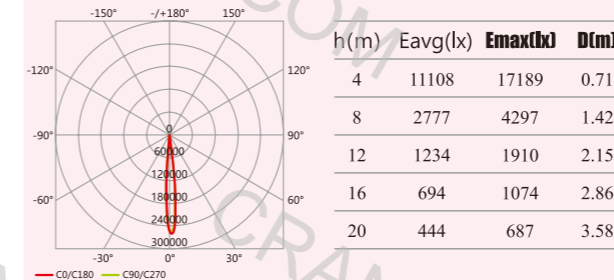

L02C-072E 150W 15°

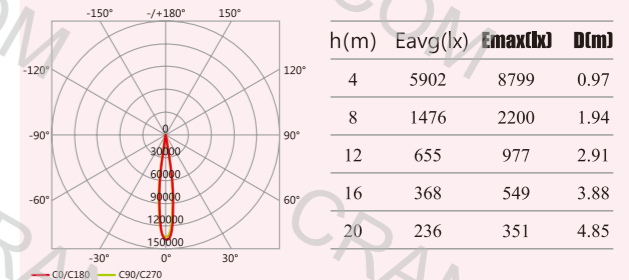

L02C-072E 150W 25°

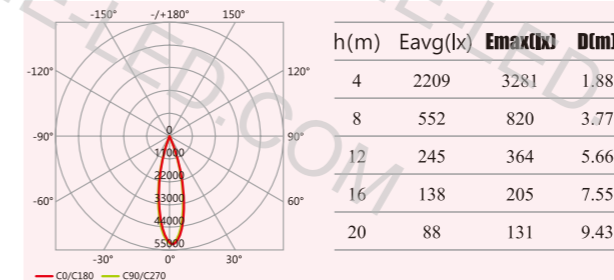

L02C-072E 150W 40°

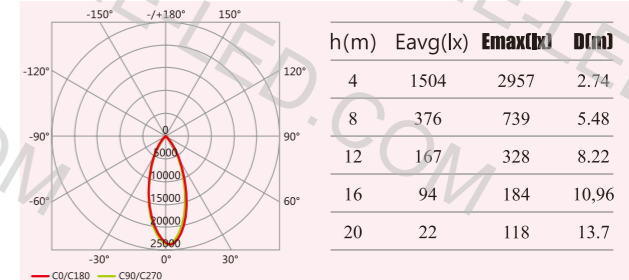

L02C-072E 150W 60°

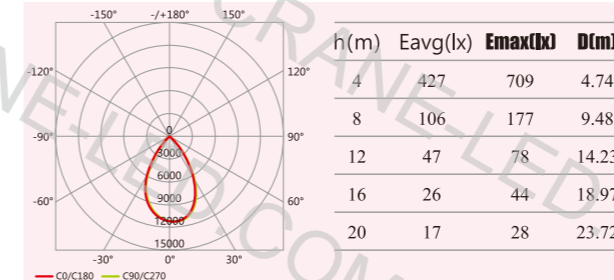

L02C-072E 150W 120°

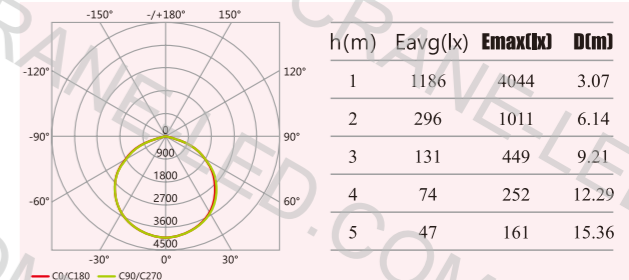

AT1

AT9



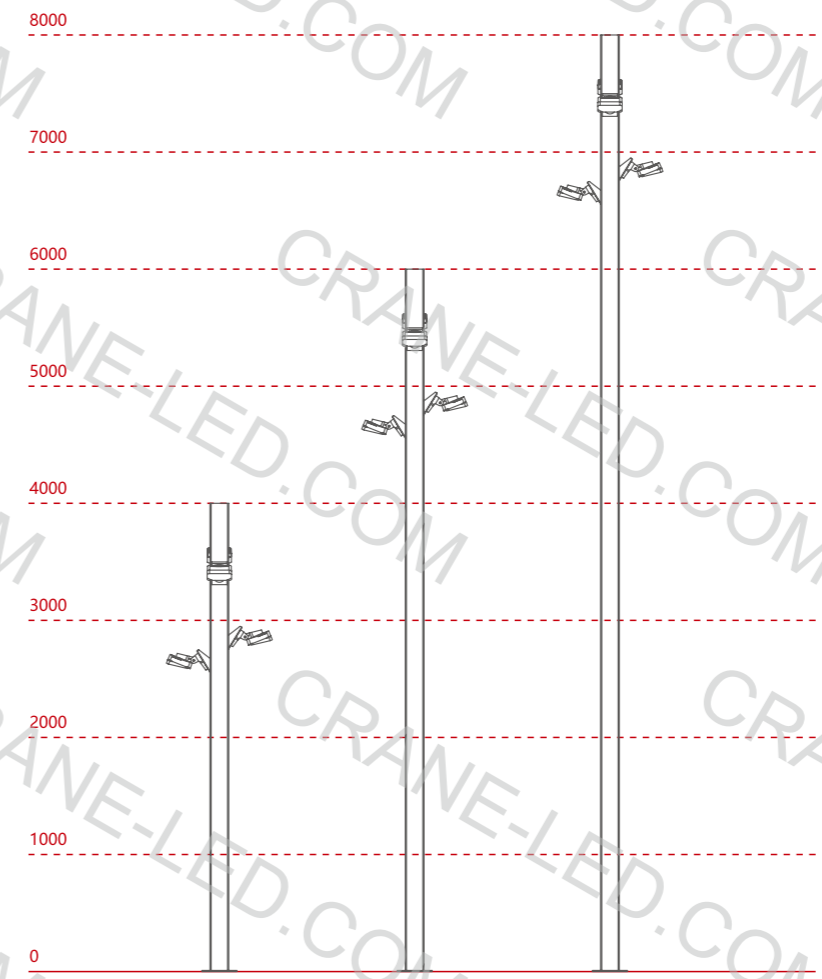
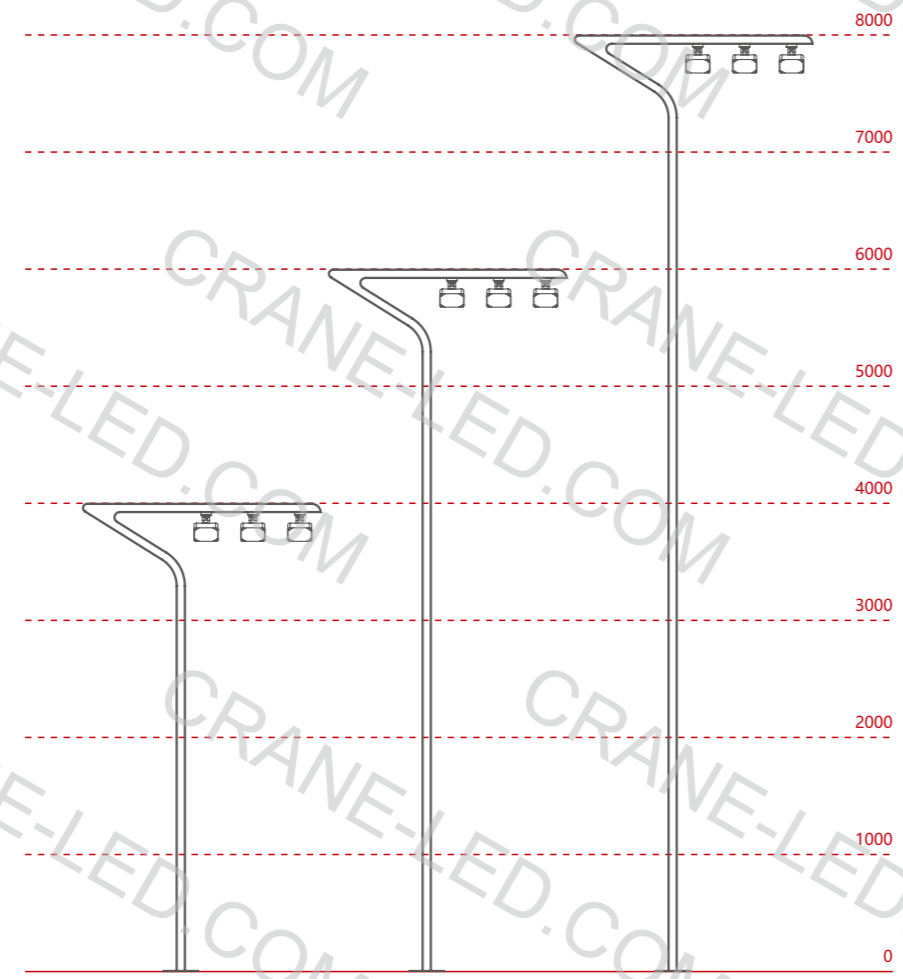
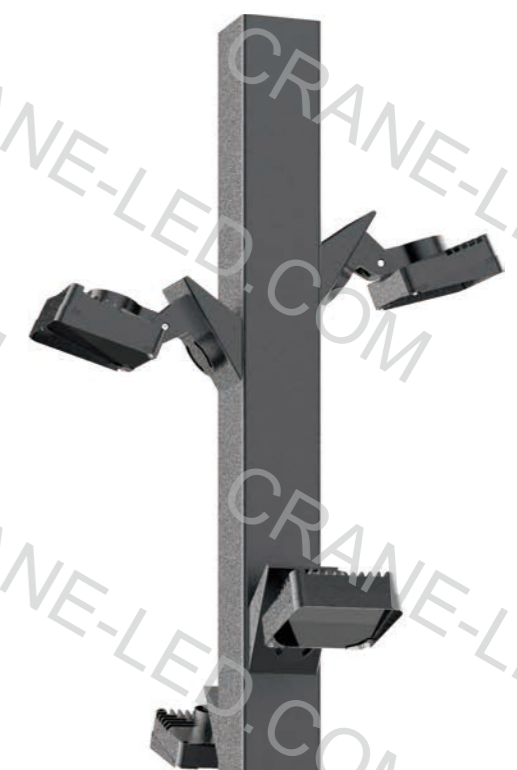
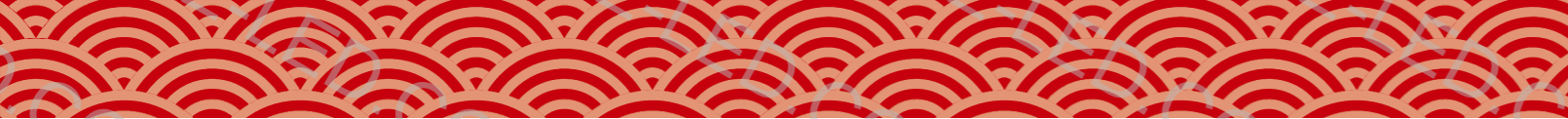

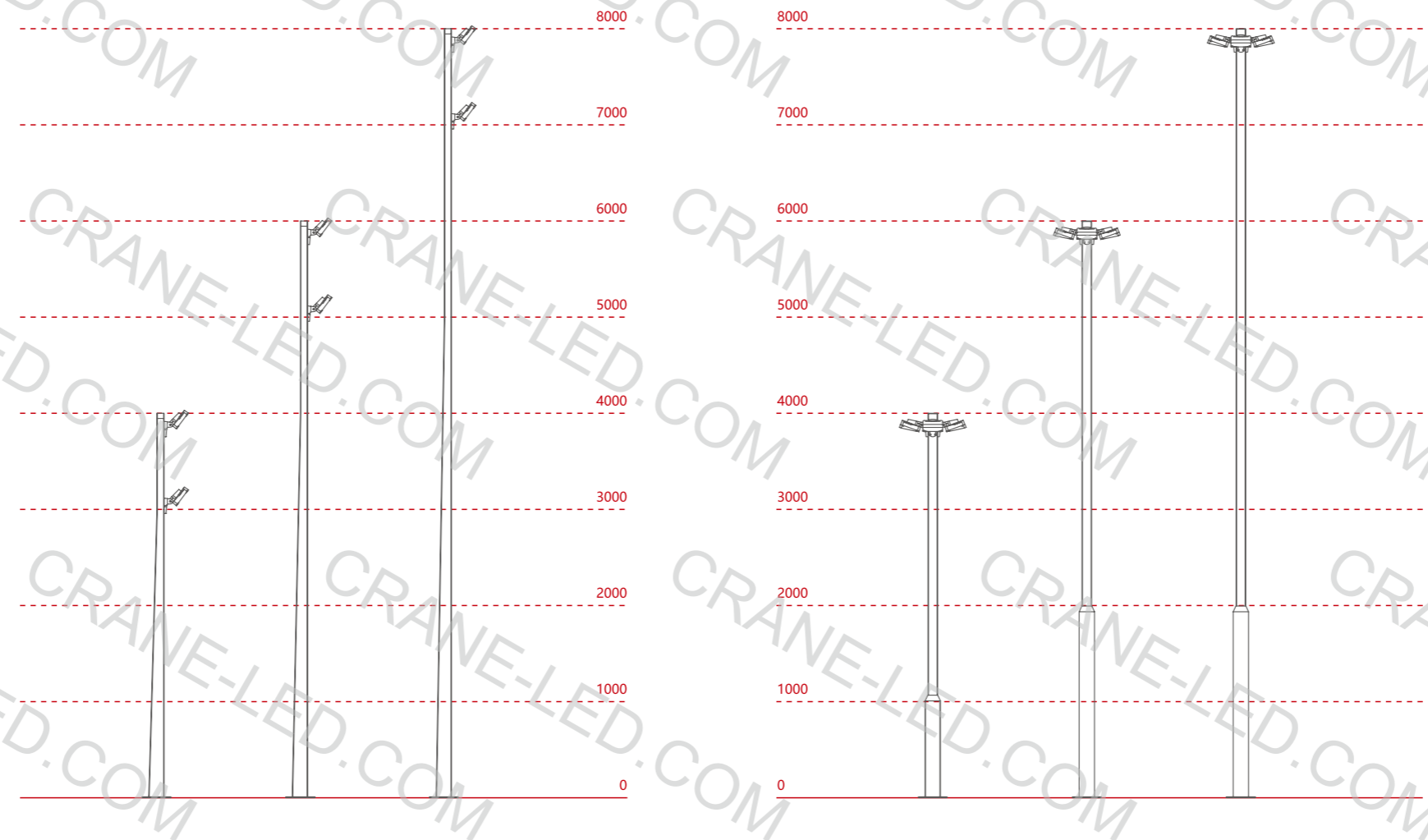
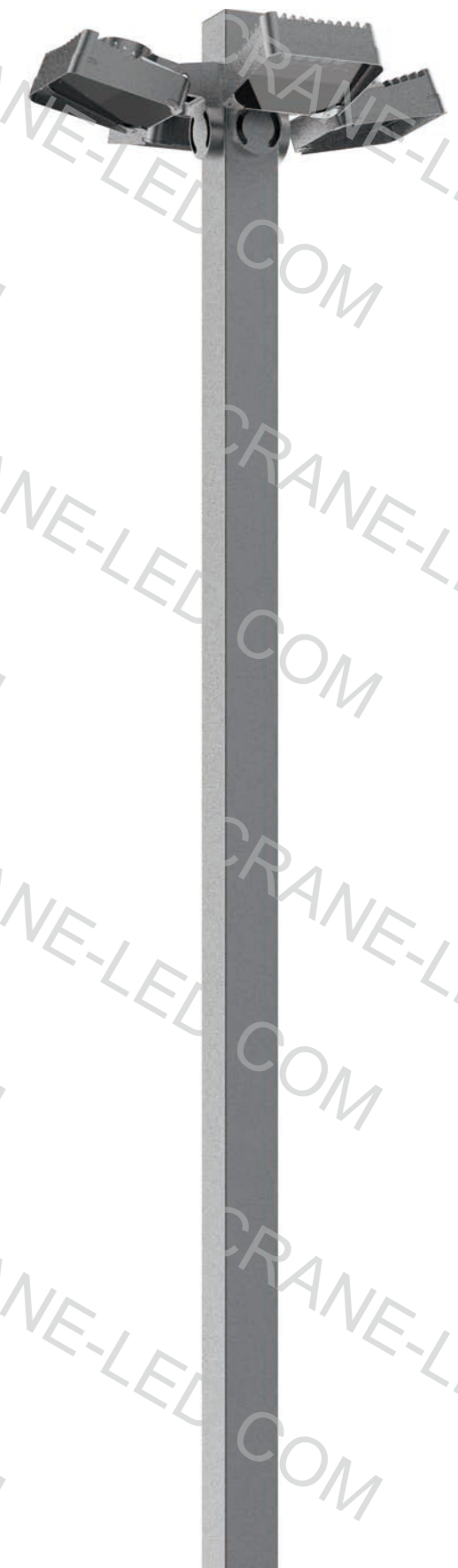
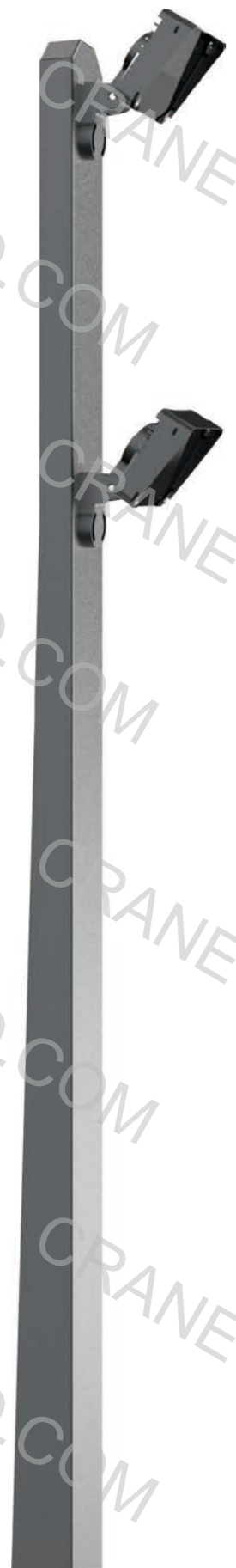
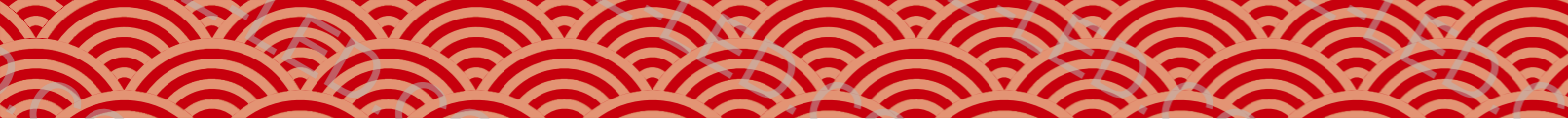

АКСЕССУАРЫ

Внешняя бленда

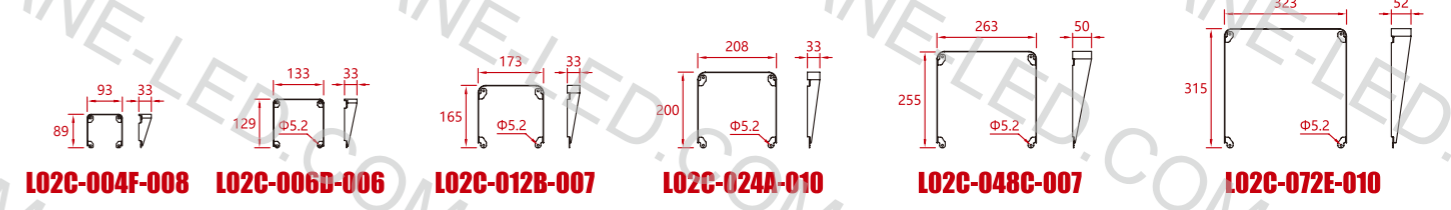
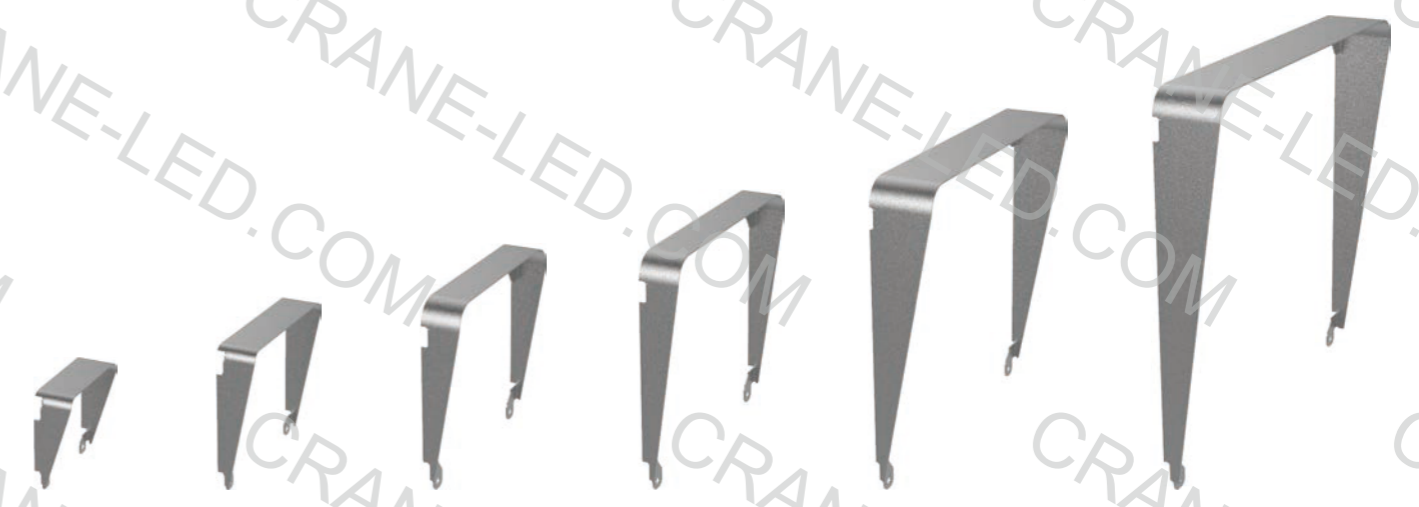

Антибликовая сетка

